



To continue its program of quality and design improvement, the manufacturer reserves the right to change specifications, design or prices without notice and without incurring obligation.

ILLUSTRATED PARTS LIST

SPACER KIT - REAR WHEELS
450 Tractor

Model Number 18515E1
Effective Date 6-15-72
Form Number 18533P1

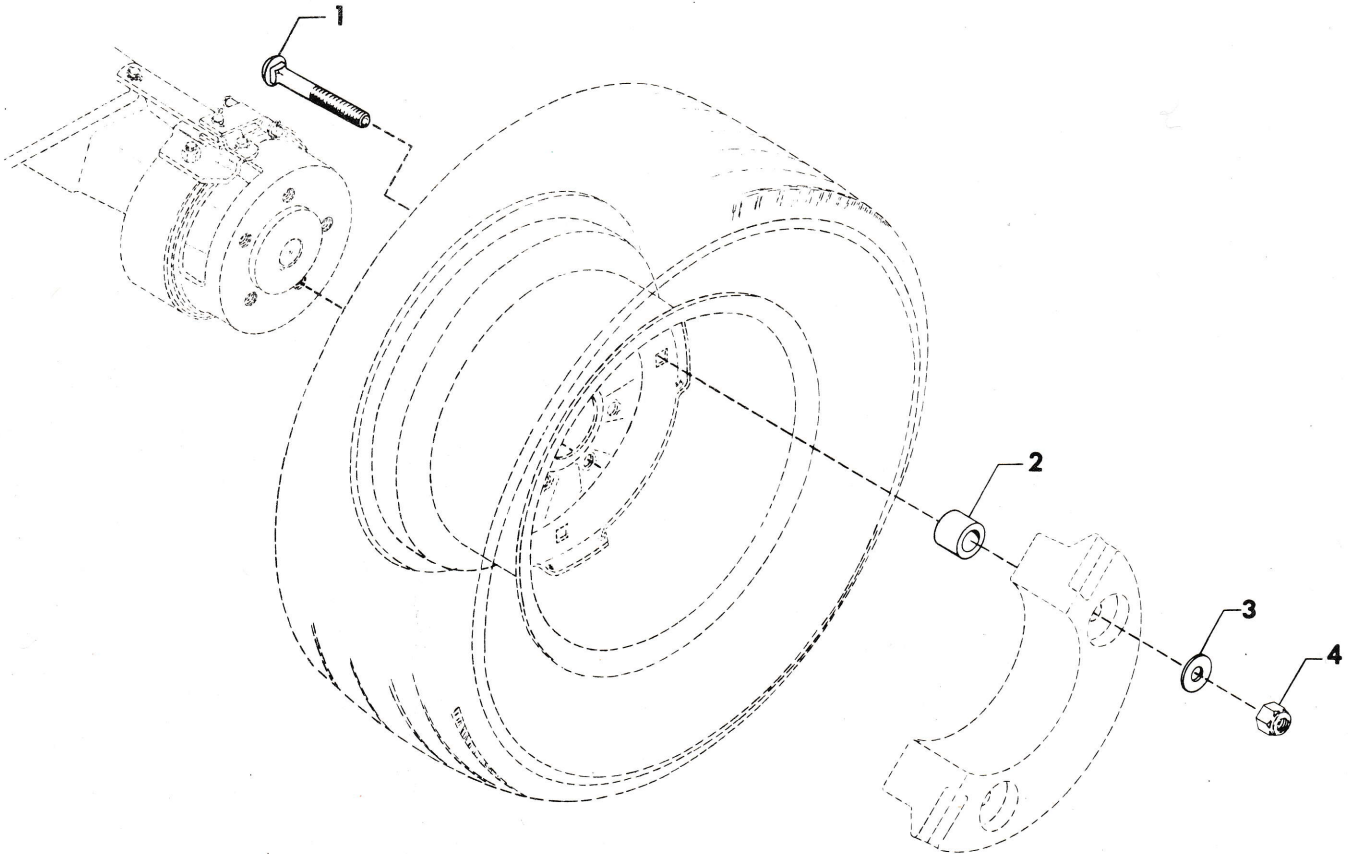

<u>ITEM NO.</u>	<u>PART NO.</u>	<u>DESCRIPTION</u>
1	125720	1/2-13 x 4-1/4 Carriage Bolt
2	18514P1	Spacer
3	9415543	17/32 x 1-1/4 x .10 Washer
4	435507	1/2-13 Washer Insert Locknut